



# User Manual

## ULTRA HIGH SPEED BURNISHER DR1500H



english	User Manual.....	1-9
deutsch	Betriebsanleitung.....	xxx
français	Notice d'utilisation .....	xxx
nederlands	Gebruiksaanwijzing.....	xxx
italiano	Istruzioni sull'uso.....	xxx
español	Instrucciones de manejo.....	xxx
português	Instruções de operação.....	xxx

### Company information:

[www.vipercleaning.eu](http://www.vipercleaning.eu)

[info-eu@vipercleaning.com](mailto:info-eu@vipercleaning.com)

41528EU (1) – 2009-01-01



**TABLE OF CONTENTS**

**INTRODUCTION ..... 2**

    MANUAL PURPOSE AND CONTENTS ..... 2

    TARGET ..... 2

    HOW TO KEEP THIS MANUAL ..... 2

    DECLARATION OF CONFORMITY ..... 2

    OTHER REFERENCE MANUALS ..... 2

    SPARE PARTS AND MAINTENANCE ..... 2

    CHANGES AND IMPROVEMENTS ..... 3

    OPERATION CAPABILITIES ..... 3

    CONVENTIONS ..... 3

**UNPACKING/DELIVERY ..... 3**

**SAFETY ..... 3**

    SYMBOLS ..... 3

    GENERAL INSTRUCTIONS ..... 4

**MACHINE DESCRIPTION ..... 6**

    MACHINE STRUCTURE ..... 6

    TECHNICAL DATA ..... 7

    WIRING DIAGRAM ..... 8

**OPERATION OF MACHINE ..... 9**

    BASIC OPERATION ..... 9

    MAINTENANCE ..... 9

    STORAGE ..... 9

## INTRODUCTION



### NOTE

*The numbers in brackets refer to the components shown in Machine Description chapter.*

## MANUAL PURPOSE AND CONTENTS

The purpose of this Manual is to provide the operator with all necessary information to use the machine properly, in a safe and autonomous way. It contains information about technical data, safety, operation, storage, maintenance, spare parts and disposal. Before performing any procedure on the machine, the operators and qualified technicians must read this Manual carefully. Contact VIPER in case of doubts concerning the interpretation of the instructions and for any further information.

## TARGET

This Manual is intended for operators and technicians qualified to perform the machine maintenance. The operators must not perform procedures reserved for qualified technicians. VIPER will not be answerable for damages coming from the non-observance of this prohibition.

## HOW TO KEEP THIS MANUAL

The User Manual must be kept near the machine, inside an adequate case, away from liquids and other substances that can cause damage to it.

## DECLARATION OF CONFORMITY

The declaration of conformity, supplied with the machine, certifies the machine conformity with the law in force.



### NOTE

*Two copies of the original declaration of conformity are provided together with the machine documentation. CE-declaration is print in Quick Start Guide*

## IDENTIFICATION DATA

The machine model and serial number are marked on the plate (1).

The machine model year is written in the declaration of conformity and it is also indicated by the first two figures of the machine serial number.

This information is useful when requiring machine spare parts. Use the following table to write down the machine identification data.

MACHINE model .....
MACHINE serial number .....

## OTHER REFERENCE MANUALS

- Service Manual (that can be consulted at VIPER Service Centers)
- Spare Parts List (see [www.vipercleaning.eu](http://www.vipercleaning.eu))

## SPARE PARTS AND MAINTENANCE

All necessary operating, maintenance and repair procedures must be performed out by qualified personnel or by VIPER Service Centers. Only original spare parts and accessories must be used.

Contact VIPER for service or to order spare parts and accessories, specifying the machine model and serial number.

## CHANGES AND IMPROVEMENTS

VIPER constantly improves its products and reserves the right to make changes and improvements at its discretion without being obliged to apply such benefits to the machines that were previously sold.

Any change and/or addition of accessories must be approved and performed by VIPER.

## OPERATION CAPABILITIES

These dragon series high speeds are used to dry cleaning solid floors, under safe operation conditions by a qualified operator.

## CONVENTIONS

Forward, backward, front, rear, left or right and up are intended with reference to the operator's position, that is to say in working position with the handle.

## UNPACKING/DELIVERY

To unpack the machine, carefully follow the instructions on the packing.

When the machine is delivered, check that the packing and the machine were not damaged during transportation. In case of visible damages, keep the packing and have it checked by the carrier that delivered it. Call the carrier immediately to fill in a damage claim.

Check that the machine is equipped with the following features:

1. Technical documents:
  - DRAGON SERIES ULTRA HIGH SPEED User Manual
  - DRAGON SERIES ULTRA HIGH SPEED Spare Parts List

## SAFETY

The following symbols indicate potentially dangerous situations. Always read this information carefully and take all necessary precautions to safeguard people and property.

The operator's cooperation is essential in order to prevent injury. No accident prevention program is effective without the total cooperation of the person responsible for the machine operation. Most of the accidents that may occur in a factory, while working or moving around, are caused by failure to comply with the simplest rules for exercising prudence. A careful and prudent operator is the best guarantee against accidents and is essential for successful completion of any prevention program.

## SYMBOLS



### DANGER!

*It indicates a dangerous situation with risk of death for the operator.*



### WARNING!

*It indicates a potential risk of injury for people or damage to objects.*



### CAUTION!

*It indicates a caution related to important or useful functions. Pay careful attention to the paragraphs marked by this symbol.*



### NOTE

*It indicates the necessity to refer to the User Manual before performing any procedure.*

## GENERAL INSTRUCTIONS

Specific warnings and cautions to inform about potential damages to people and machine are shown below.



### DANGER!



- *Always disconnect the power supply cable when the machine is not in use, before performing maintenance procedures, before replacing the brush/pad-holder and before opening any access panel.*
- *This machine must be used by properly trained and authorised personnel only. Children or disabled people cannot use this machine.*
- *Do not wear jewels when working near electrical components.*
- *Do not work under the lifted machine without supporting it with safety stands.*
- *Do not operate the machine near toxic, dangerous, flammable and/or explosive powders, liquids or vapours.*



### WARNING!



- *The machine power supply cable is grounded and the relevant plug is grounded too. In case of machine malfunction or breakdown, grounding connection reduces the risk of electric shock.*
- *The power supply cable plug must be connected to an appropriate outlet, which is grounded according to law in force.*
- *This appliance is not intended for use by persons (including children) with reduced physical, sensory or mental capabilities, or lack of experience and knowledge, unless they have been given supervision or instruction concerning use of the appliance by a person responsible for their safety.*
- *Children should be supervised to ensure that they do not play with the appliance.*
- *If the supply cord is damaged, it must be replaced by the manufacturer, its service agent or similarly qualified persons in order to avoid a hazard.*
- *Improper connection can cause electric shock. Consult a qualified technician to make sure that the outlet is properly grounded.*
- *Do not tamper with the power supply cable plug. If the power supply cable plug cannot be connected to the outlet, have new grounded outlet installed by a qualified technician, according to the law in force.*
- *Before connecting the power supply cable to the electrical mains, check that frequency and voltage, shown on the machine serial number plate, match the electrical mains voltage.*
- *Regularly check the power supply cable for damages, cracks, cuts, etc. If the power supply cable is damaged, replace it immediately.*
- *To avoid any risk, if the power supply cable is damaged, contact VIPER Service Center or a qualified technician.*
- *Do not pull or carry the machine by the power supply cable and never use the power supply cable as a handle. Do not close a door on the power supply cable, or pull the power supply cable around sharp edges or corners. Do not run the machine on the power supply cable.*
- *Keep the power supply cable away from heated surfaces.*
- *To reduce the risk of fire, electric shock, or injury, do not leave the machine unattended when it is plugged in. Disconnect the machine from the electrical mains when not in use and before performing maintenance procedures.*
- *To avoid electric shock, do not expose the machine to rain or other bad weather conditions. Store the machine indoors, in a dry place.*
- *Do not allow to be used as a toy. Close attention is necessary when used near children.*
- *Use only as shown in this Manual. Use only VIPER'S recommended accessories.*
- *Take all necessary precautions to prevent hair, jewels and loose clothes from being caught by the machine moving parts.*
- *Do not leave the machine unattended without being sure that it cannot move independently.*
- *Do not use the machine on slopes with a gradient exceeding the specifications.*
- *Do not use the machine in particularly dusty areas.*
- *While using this machine, take care not to cause damage to people or objects.*
- *Do not bump into shelves or scaffoldings, especially where there is a risk of falling objects.*
- *Do not put any can containing fluids on the machine.*
- *The machine working temperature must be between 0°C and +40°C.*
- *The machine storage temperature must be between 0°C and +40°C.*

- *The humidity must be between 30% and 95%.*
- *Do not use the machine as a means of transport.*
- *Do not use the machine on slopes with a gradient exceeding the specifications.*
- *Do not allow the brush/pad to operate while the machine is stationary to avoid damaging the floor.*
- *In case of fire, use a powder fire extinguisher, not a water one.*
- *Do not tamper with the machine safety guards and follow the ordinary maintenance instructions scrupulously.*
- *Do not allow any object to enter into the openings. Do not use the machine if the openings are clogged. Always keep the openings free from dust, hairs and any other foreign material which could reduce the air flow.*
- *Do not remove or modify the plates affixed to the machine.*
- *If the machine is used according to the instructions, the vibrations are not dangerous. The machine vibration level is less than 2.5 m/s<sup>2</sup> (98/37/EEC-EN 1033/1995).*
- *This machine cannot be used on roads or public streets.*
- *Pay attention during machine transportation when temperature is below freezing point. The water in the recovery tank or in the hoses could freeze and seriously damage the machine.*
- *Use brushes and pads supplied with the machine and those specified in the User Manual. Using other brushes or pads could reduce safety.*
- *In case of machine malfunctions, ensure that these are not due to lack of maintenance. If necessary, request assistance from the authorised personnel or from VIPER Service Center.*
- *If the machine*
  - *does not work properly*
  - *is damaged*
  - *has water or foam leaks*
  - *has been left outdoors exposed to bad weather conditions*
  - *is wet or has been dropped into water*
- *turn it off immediately and contact VIPER Service Center or a qualified technician.*
- *If parts must be replaced, require ORIGINAL spare parts from VIPER Dealer or Retailer.*
- *To ensure machine proper and safe operation, the scheduled maintenance shown in the relevant chapter of this Manual, must be performed by the authorised personnel or by VIPER Service Center.*
- *Carefully read all the instructions before performing any maintenance/repair procedure.*
- *Do not wash the machine with direct or pressurised water jets, or with corrosive substances.*
- *The machine must be disposed of properly, because of the presence of toxic-harmful materials (batteries, electrical components, etc.), which are subject to standards that require disposal in special centres (see Scrapping chapter).*

**MACHINE DESCRIPTION**

- Handle mounted handle release
- Die-cast aluminum deck
- Folding handle for easy storage
- Safety lock-out switch
- Flexible pad driver
- Large rear transport wheels
- Handle-mounted circuit breaker

**MACHINE STRUCTURE**

- |                 |                           |
|-----------------|---------------------------|
| 1. Rating plate | 2. Folding handle         |
| 3. Handle grip  | 4. Safety lock-out button |
| 5. Bumper       | 6. Deck                   |
| 7. Wheel        |                           |



**TECHNICAL DATA**

<b>Model</b>	<b>DR1500H</b>
Voltage	220-240 V
Power	1100 W
Current	6.5 A
Frequency	50-60 Hz
RPM	1500
Deck Size	20" (51 cm)
Length of Power cord	15 m
Weight	39 Kg
Dimensions	L: 83.8 cm
	W: 53.3 cm
	H: 120.6 cm

WIRING DIAGRAM FOR DR1500H

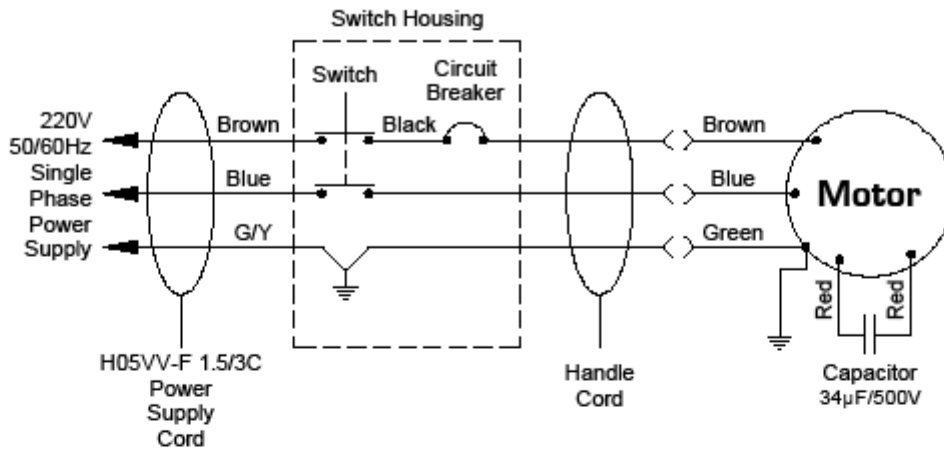

## OPERATION OF ULTRA HIGH SPEED FLOOR MACHINE

### BASIC OPERATION

- 1] Remove any obstructions or other obstacles in the area which is to be cleaned.
- 2] Place handle in upright position and tilt machine back until handle rests on the floor.  
**\*Be sure the machine is not plugged into an outlet.**
- 3] Remove the pad center gripping device by unscrewing the thumbscrews.
- 4] Place appropriate burnishing pad on pad driver and re-attach the center gripping device.
- 5] Place machine back into its upright position.
- 6] Plug power cord into grounded outlet.  
**\*Do not use an extension cord in conjunction with the standard power cord.**
- 7] Adjust the handle (switch housing) height to a comfortable operating position.
- 8] To start the machine, push on the Red safety button of the top of upper switch housing and squeeze either of the switch levers.
- 9] When the machine is in operation, both hands should be placed on the handle (switch housing).
- 10] To stop the machine at any time, simply release the switch lever, and the machine will stop automatically.

### MAINTENANCE

To keep the machine performing well for many years, please follow the following maintenance procedures.

**\* Always confirm that the machine is unplugged prior to performing any maintenance or repairs.**

- 1] Unplug machine as soon as you are not using it.
- 2] Clean the outside of the machine with a mild cleaner.
- 3] Check power cord for any damage. If any damage is detected, replace the cord immediately.
- 4] Lubricate wheels with a water resistant lubricant every month.
- 5] Check machine for loose or missing nuts and bolts, and replace as necessary.
- 6] If the machine is used in a dusty environment, you may remove the motor cover and blow the motor clean with compressed air. This will allow for good ventilation and help the motor run cooler.

### STORAGE

- 1] Unplug machine from power source.
- 2] Store in upright position in a dry area.



Do not dispose of electrical appliances as unsorted municipal waste, use separate collection facilities.